

1 Pre-Check

This section is designed as a conceptual check for you to determine if you conceptually understand and have any misconceptions about this topic. Please answer true/false to the following questions, and include an explanation:

- 1.1 Simplifying boolean logic expressions will not affect the performance of the hardware implementation.

- 1.2 The fewer logic gates, the faster the circuit (assuming each gate has the same propagation delays).

- 1.3 The time it takes for clock-to-q and register setup can be greater than one clock cycle.

- 1.4 Every possible combinational logic circuit can be expressed by some combination of NOR gates.

- 1.5 The shortest combinational logic path between two state elements is useful in determining circuit frequency and minimum clock cycle.

2 Logic Gates

2.1 Label the following logic gates:

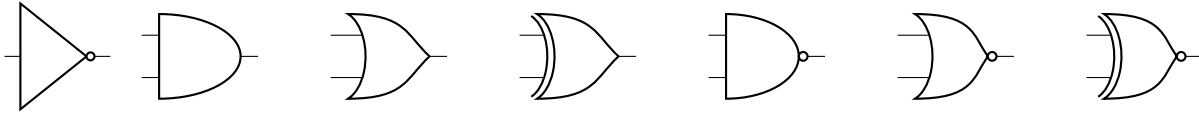

2.2 Convert the following to simplified boolean expressions on input signals A and B. Remember that simplified boolean expressions should only have NOT, AND, and OR primitives (\bar{A} , \times , and $+$ respectively):

(a) NAND

(b) XOR

(c) XNOR

2.3 Create an AND gate using only NAND gates.

2.4 How many different two-input logic gates can there be? How many n -input gates?

3 Combinational Logic Design

Logic gates can be connected together to create a variety of useful functions. In this question, we will implement a simplified version of the memory write mask for the RISC-V CPU. The memory write mask looks at the store instruction given and decides which of the four bytes (in one word of memory) to write to. It is four bits long - each bit is one if we should write to the corresponding byte, but zero if we shouldn't. For simplicity, assume that all memory addresses used in store instruction are word-aligned. Here's a truth table for the simplified memory mask:

Instruction	funct3	Out
sb	000	0001
sh	001	0011
sw	010	1111
(undefined)	011-111	xxxx

The x's for the final entry of the table indicates that any output is fine in that case.

- 3.1 Write out and simplify boolean expressions for each of the output bits in terms of the funct3 (input) bits f_2, f_1, f_0 .

- 3.2 Draw out the boolean circuit for this memory write mask based on your simplified expressions above. You may use constants 0 and 1, and the logic gates AND, OR, NOT.

4 State Intro

There are two basic types of circuits: combinational logic circuits and state elements. **Combinational logic** circuits simply change based on their inputs after whatever propagation delay is associated with them. For example, if an AND gate (pictured below) has an associated propagation delay of 2ps, its output will change based on its input as follows:

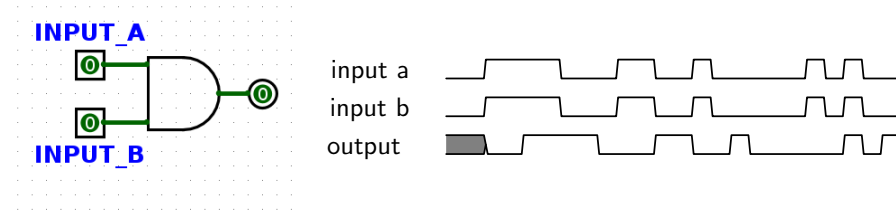

You should notice that the output of this AND gate *always* changes 2ps after its inputs change.

State elements, on the other hand, can *remember* their inputs even after the inputs change. State elements change value based on a clock signal. A rising edge-triggered register, for example, samples its input at the rising edge of the clock (when the clock signal goes from 0 to 1).

Like logic gates, registers also have a delay associated with them before their output will reflect the input that was sampled. This is called the **clk-to-q** delay. (“Q” often indicates output). This is the time between the rising edge of the clock signal and the time the register’s output reflects the input change.

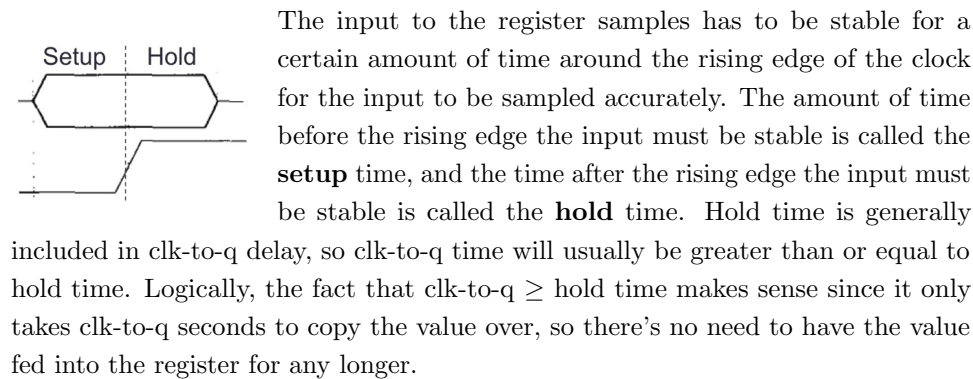

For the following register circuit, assume **setup** of 2.5ps, **hold** time of 1.5ps, and a **clk-to-q** time of 1.5ps. The clock signal has a period of 13ps.

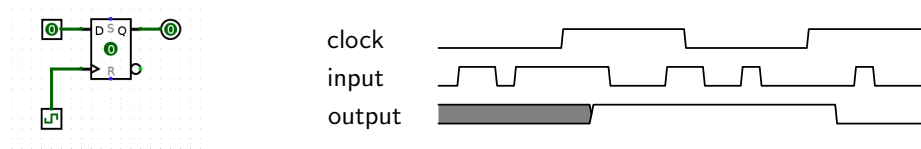

You’ll notice that the value of the output in the diagram above doesn’t change immediately after the rising edge of the clock. Until enough time has passed for the output to reflect the input, the value held by the output is garbage; this is represented by the shaded gray part of the output graph. Clock cycle time must be small enough that inputs to registers don’t change within the hold time and large enough to account for clk-to-q times, setup times, and combinational logic delays.

- 4.1 For the following 2 circuits, fill out the timing diagram. The clock period (rising edge to rising edge) is 8ps. For every register, clk-to-q delay is 2ps, setup time is 4ps, and hold time is 2ps. NOT gates have a 2ps propagation delay, which is already accounted for in the !clk signal given.

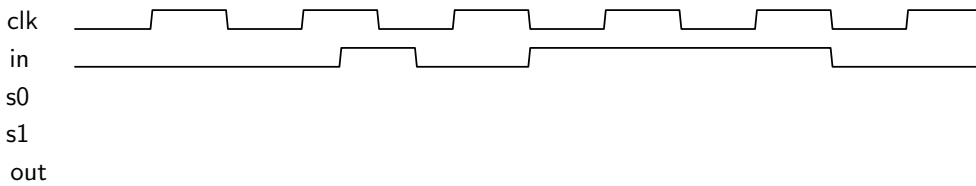
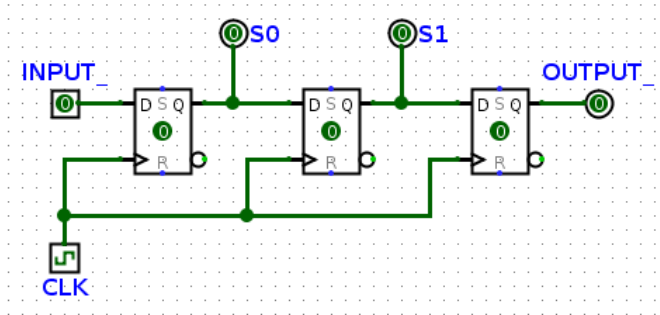
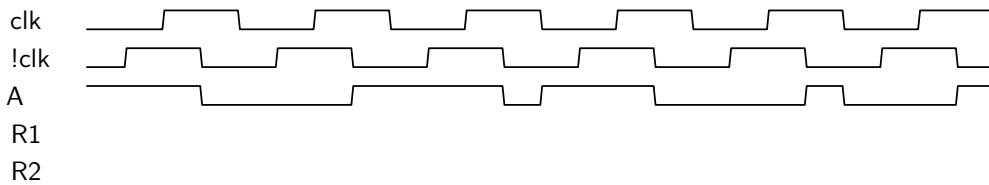
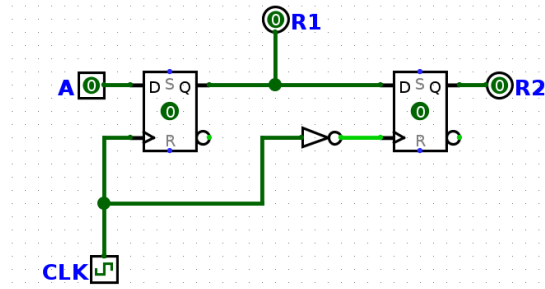

- 4.2 In the circuit below, RegA and RegB have setup, hold, and clk-to-q times of 4ns, all logic gates have a delay of 5ns, and RegC has a setup time of 6ns. What is the maximum allowable hold time for RegC? What is the minimum acceptable clock cycle time for this circuit, and clock frequency does it correspond to?

